

**February 12, 2026**

**LINKWOOD ROAD  
SIDEWALK  
INSTALLATION**

Public Information Open House

**CITY OF ATLANTA**



**DEPARTMENT OF TRANSPORTATION**

Mayor Andre Dickens

ATLDOT Commissioner Solomon Caviness IV

# Moving Atlanta Forward Pillars



**Moving Atlanta Forward**

- One Safe City
- A City of Opportunity for All
- A City Built for the Future
- Effective and Ethical Government

# Agenda



**6:00 – 6:05 P.M.**

Welcome

**6:05 – 6:10 P.M.**

Project Team

**6:10 – 6:30 P.M.**

Project Overview

**6:30 – 6:50 P.M.**

Community Discussion

**6:50 – 7:00 P.M.**

Closing Remarks



# PROJECT TEAM



# Project Team



## **Andrea L. Boone**

City of Atlanta Councilmember (District 10)

## **Solomon Caviness IV**

Commissioner, ATLDOT

## **Lenor Bromberg, PE**

Deputy Commissioner, Engineering, ATLDOT

## **Dameon Simmons, PMP**

Program Manager, ATLDOT

## **Raj Shah, PE**

Project Manager, ATLDOT

## **Bryan Ricks, PE, MBA**

Consultant Project Manager, RS&H, Inc.

# Project History & Benefits

- **Initiated by the public's request to extend sidewalk along Linkwood Road**
- **Supported by District 10 council member**
- **Serves as a connection to existing and proposed sidewalks and paths**
- **Provides improved pedestrian flow along corridor**
- **Easements will be needed for construction of slopes and driveways**



# PROJECT OVERVIEW

# Linkwood Road Sidewalk Installation Project Map



# Project Description

## SIDEWALK AND ADA RAMP UPGRADES

- **Installation of new sidewalks to provide continuous pedestrian access**
  - Continuous 6' sidewalk from Collier Dr NW to MLK Jr Dr / SR 139
  - Restriping, pedestrian crossing improvements, American with Disabilities Act (ADA) upgrades
  - Drainage assessment and repair and curbing along east side of Linkwood Rd
- **Connection to Project #4049 Burton Rd Sidewalk Installation**
- **Connection to existing trail along MLK Jr Dr**
- **Pedestrian improvements to MARTA stops (Bus Route 856) along Linkwood Rd via sidewalk**

## Linkwood Road Sidewalk Installation

# Project Status

## CURRENT PHASE: ENGINEERING/DESIGN

- **September 2025: Notice to proceed for design**
- **October 2025: Start of site survey work**
- **January 2026: Survey data collection completed**
- **February 2026: Public Information Open House**
- **July 2026: Anticipated completion of 30% Preliminary Design**

# Linkwood Road from Collier Dr to Linkwood PI

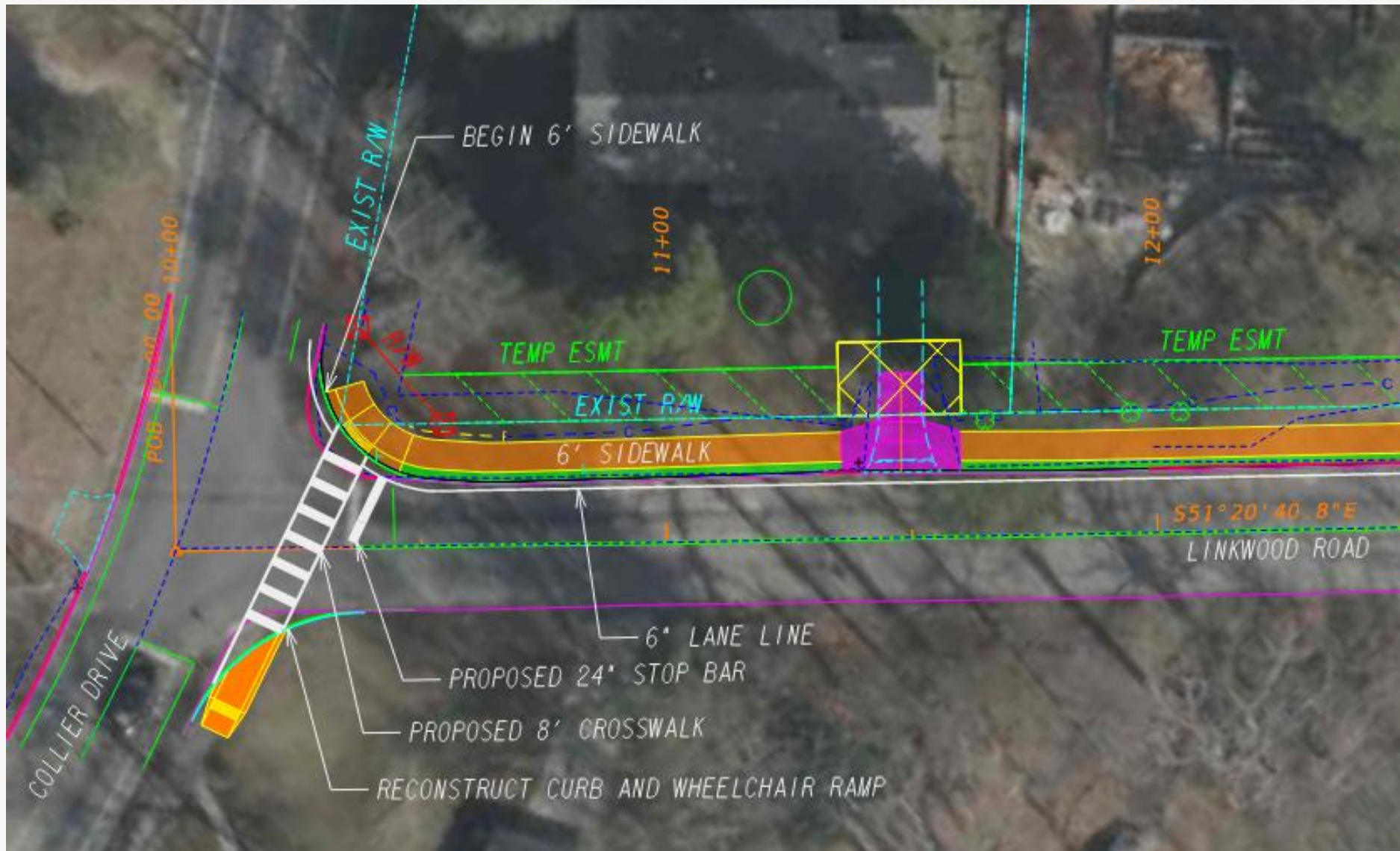

Plan View

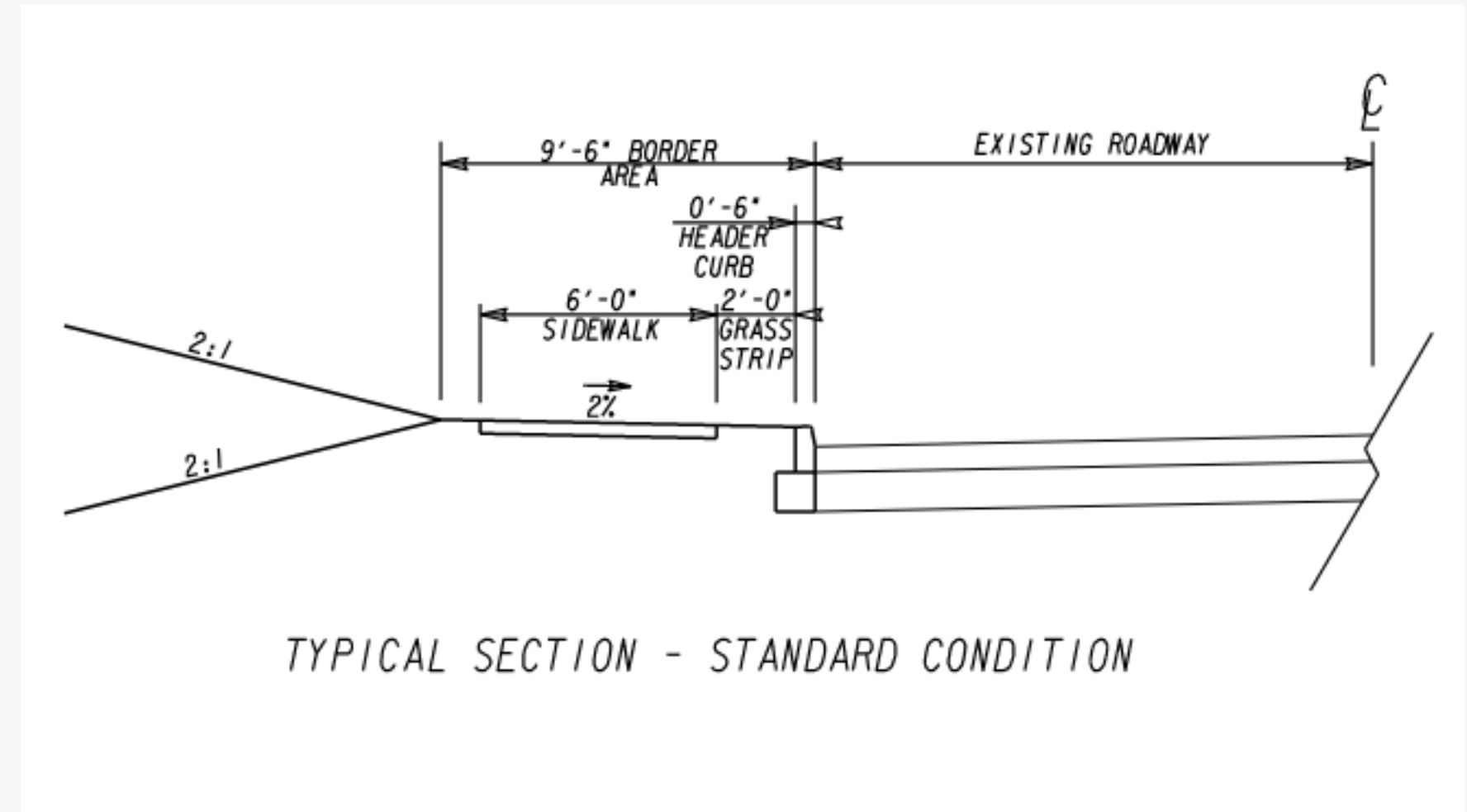

# Linkwood Road at Linkwood PI

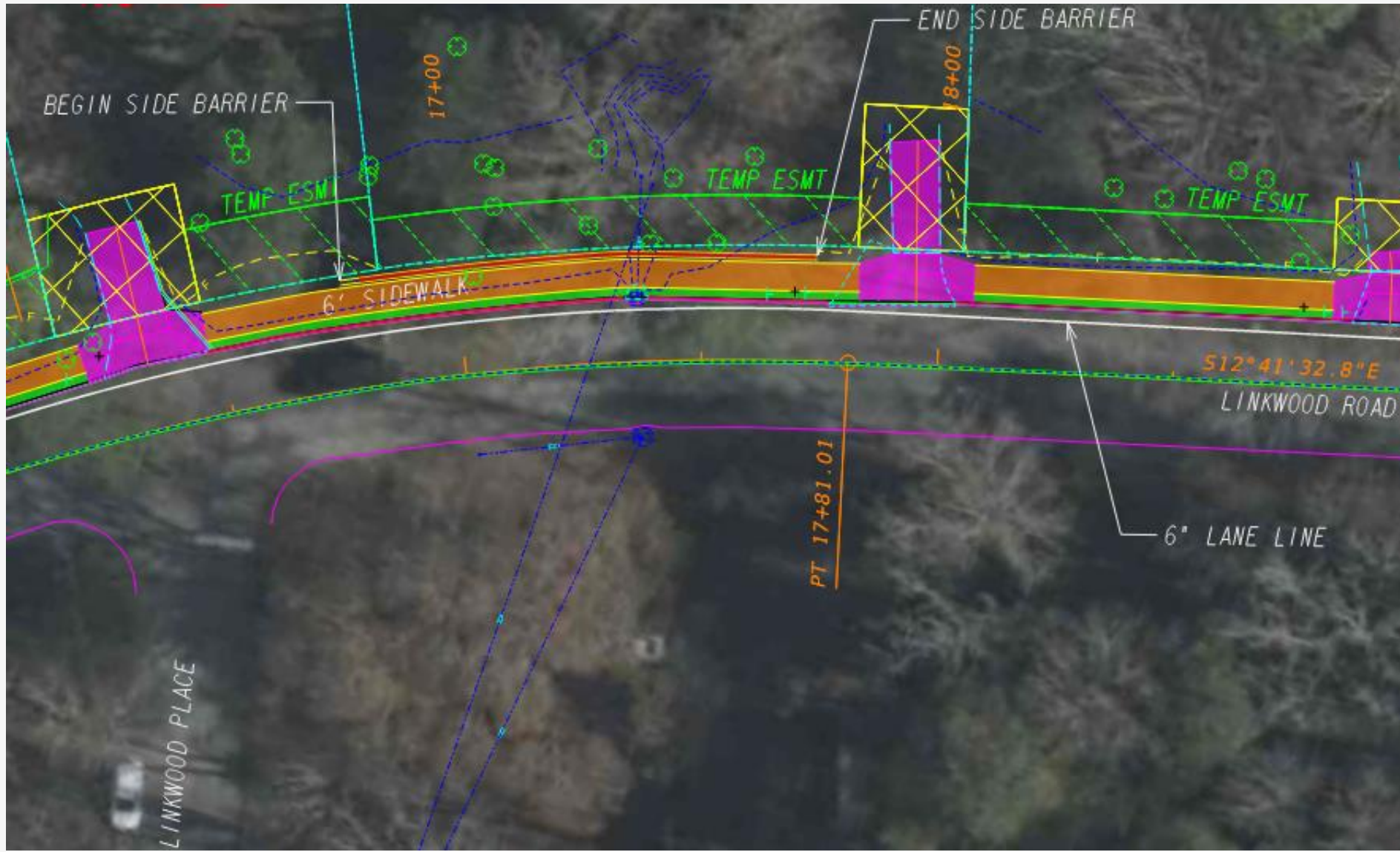

Plan View

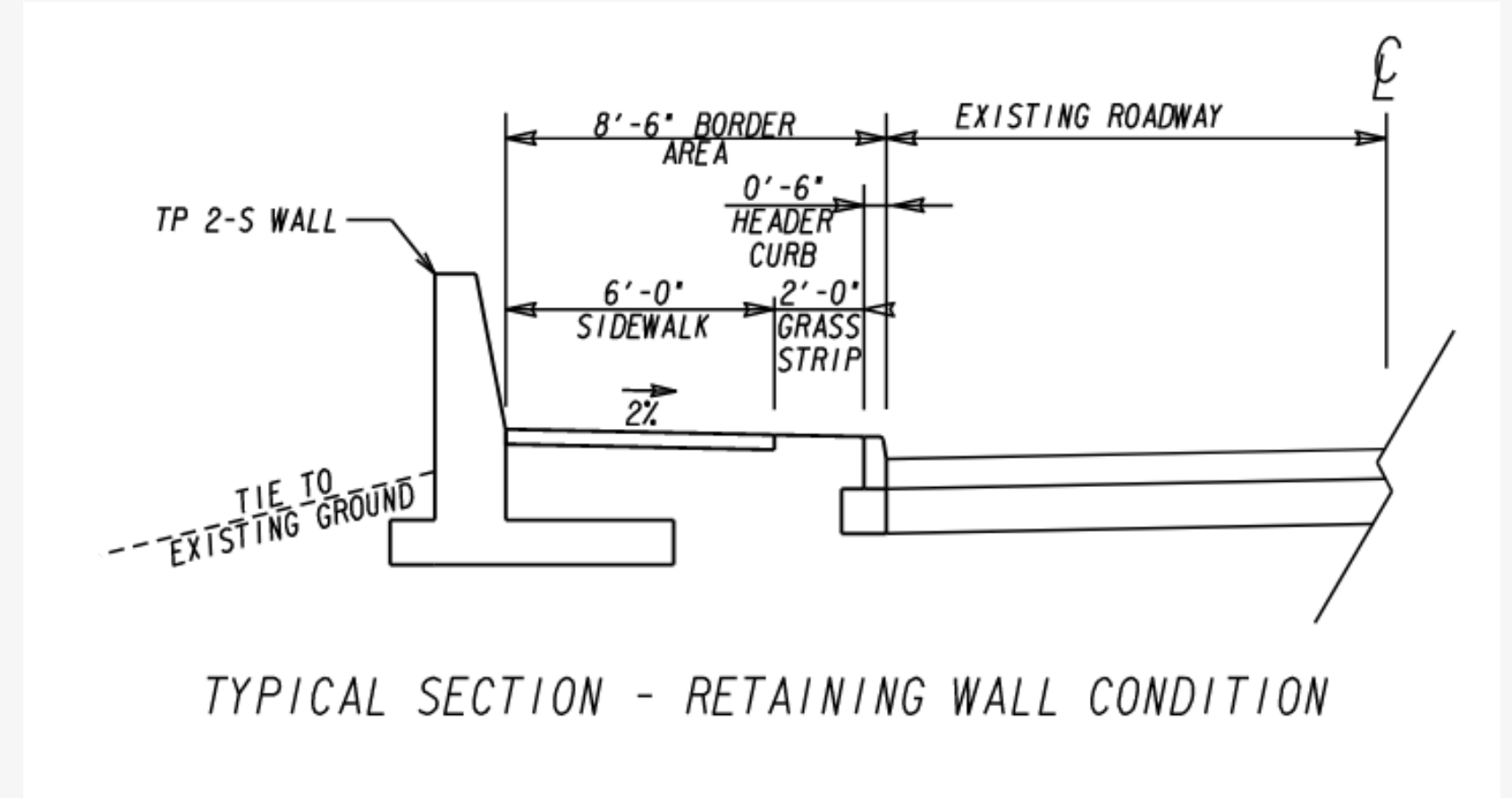

# Linkwood Road from Linkwood PI to I-20 Bridge



Plan View

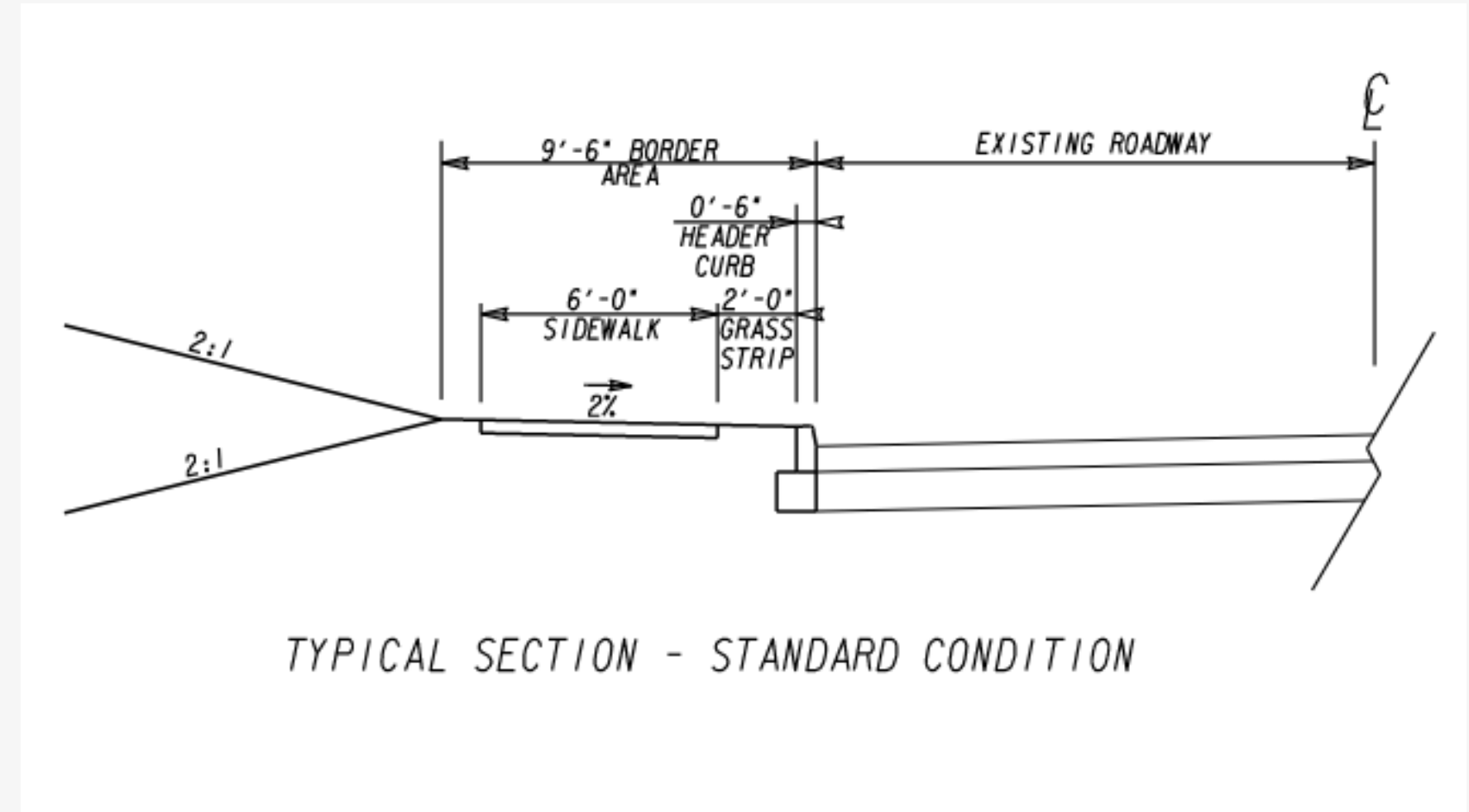

# Linkwood Road connecting to I-20 Bridge

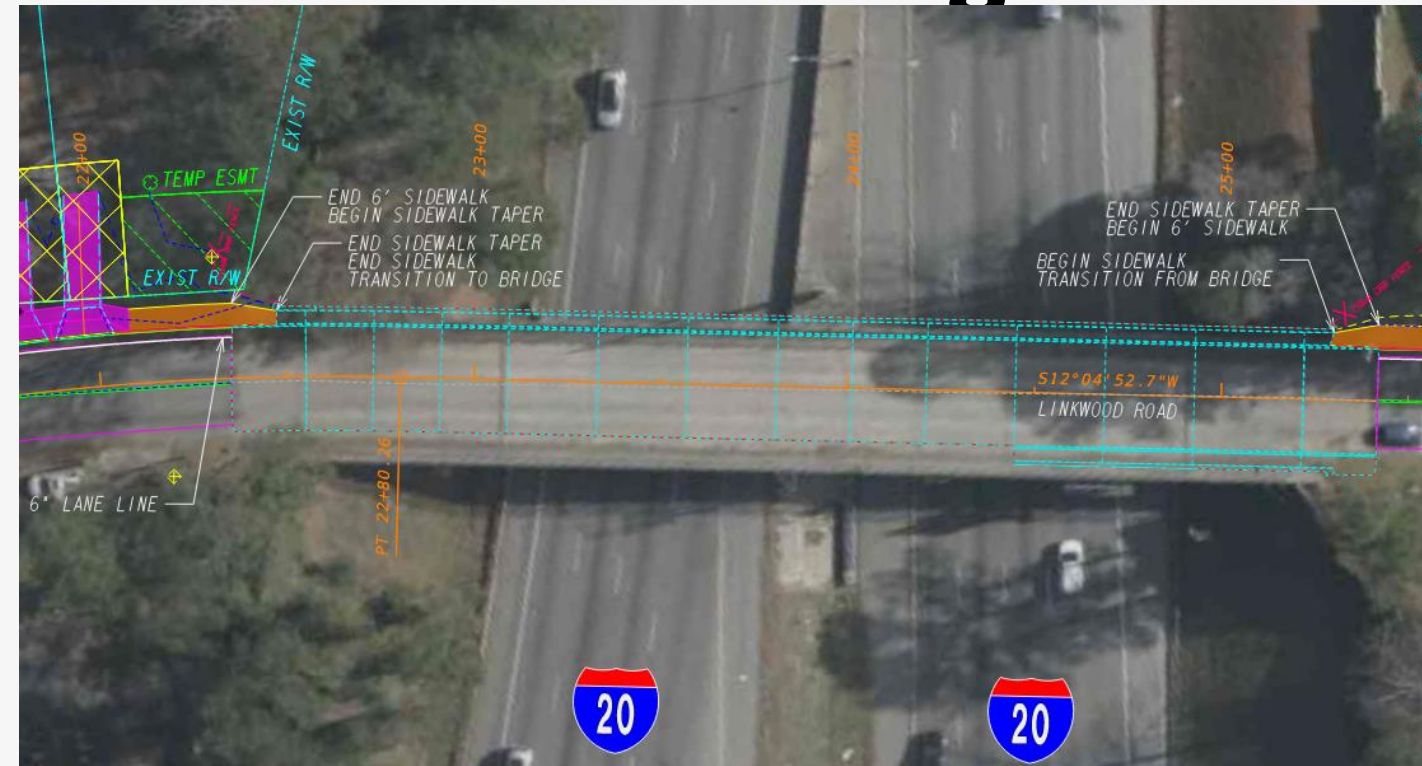

Plan View

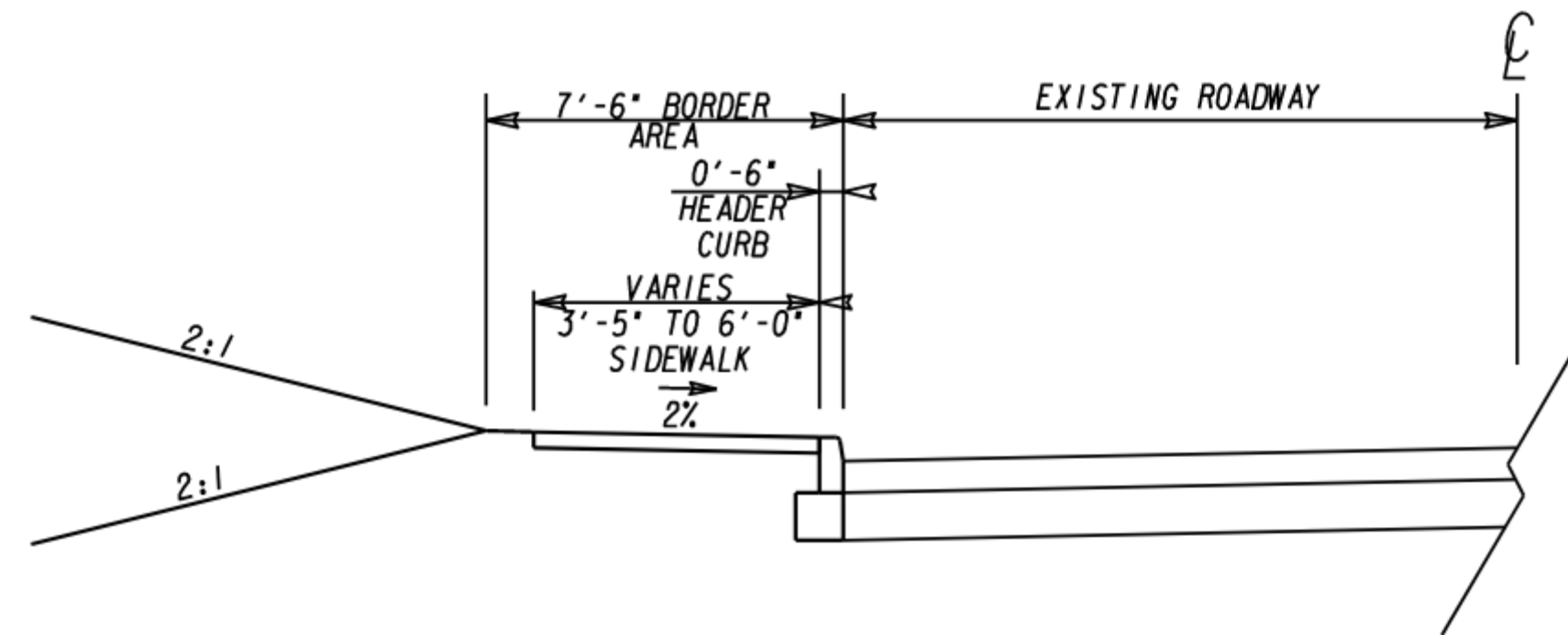

TYPICAL SECTION - NARROW WIDTH CONDITION

# Linkwood Road from I-20 Bridge to Delmar Ln

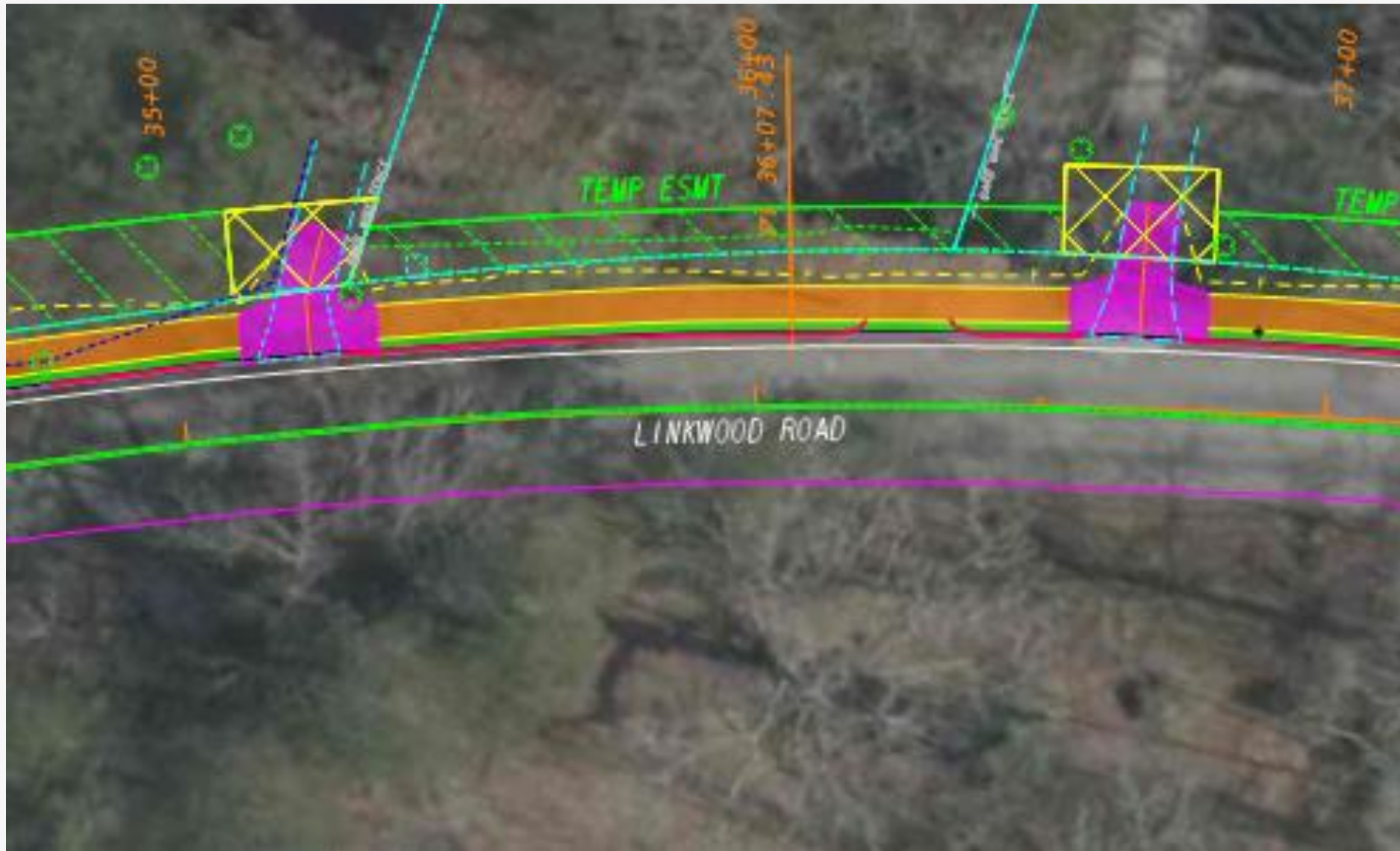

Plan View

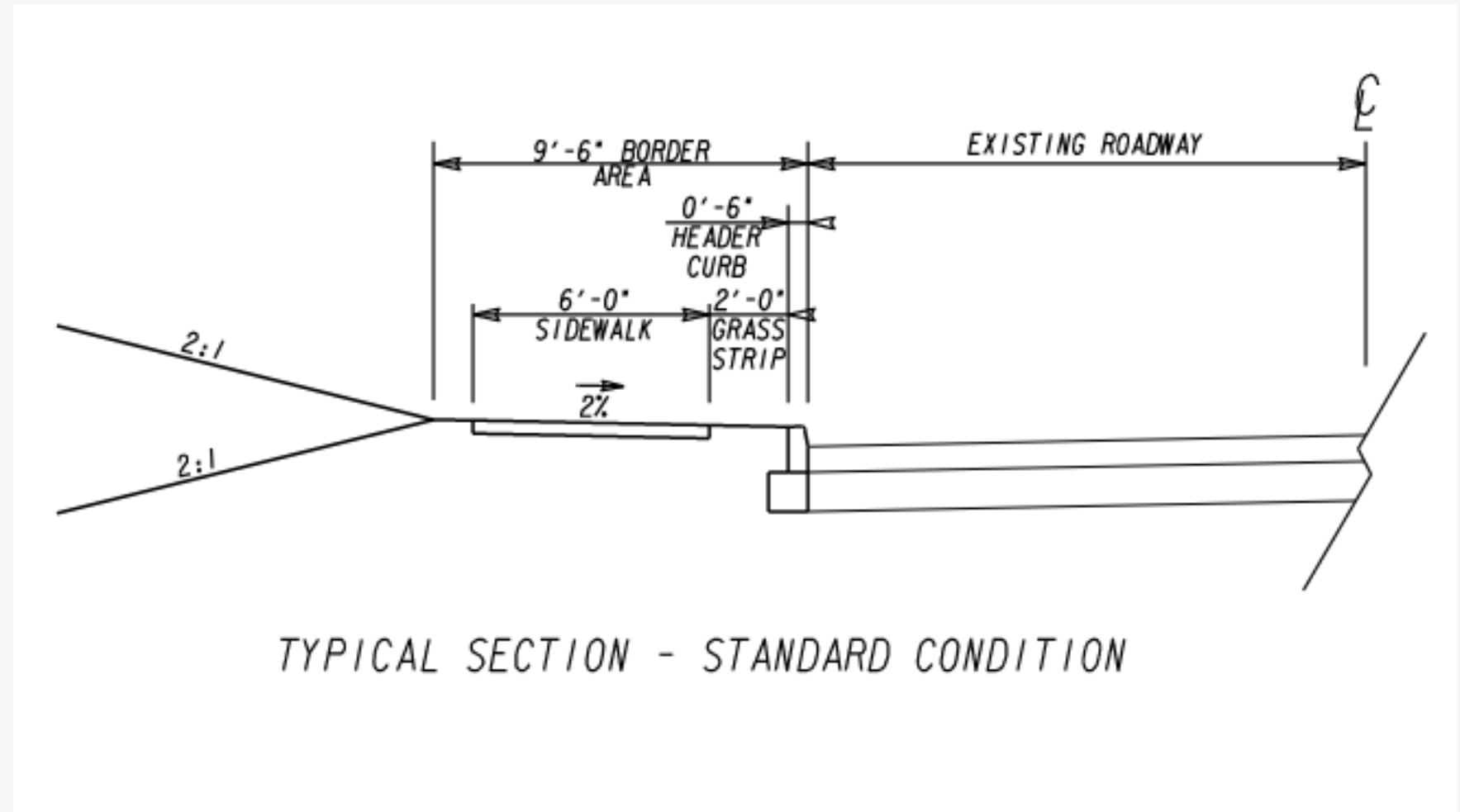

# Linkwood Road from Delmar Ln to MLK Jr Dr

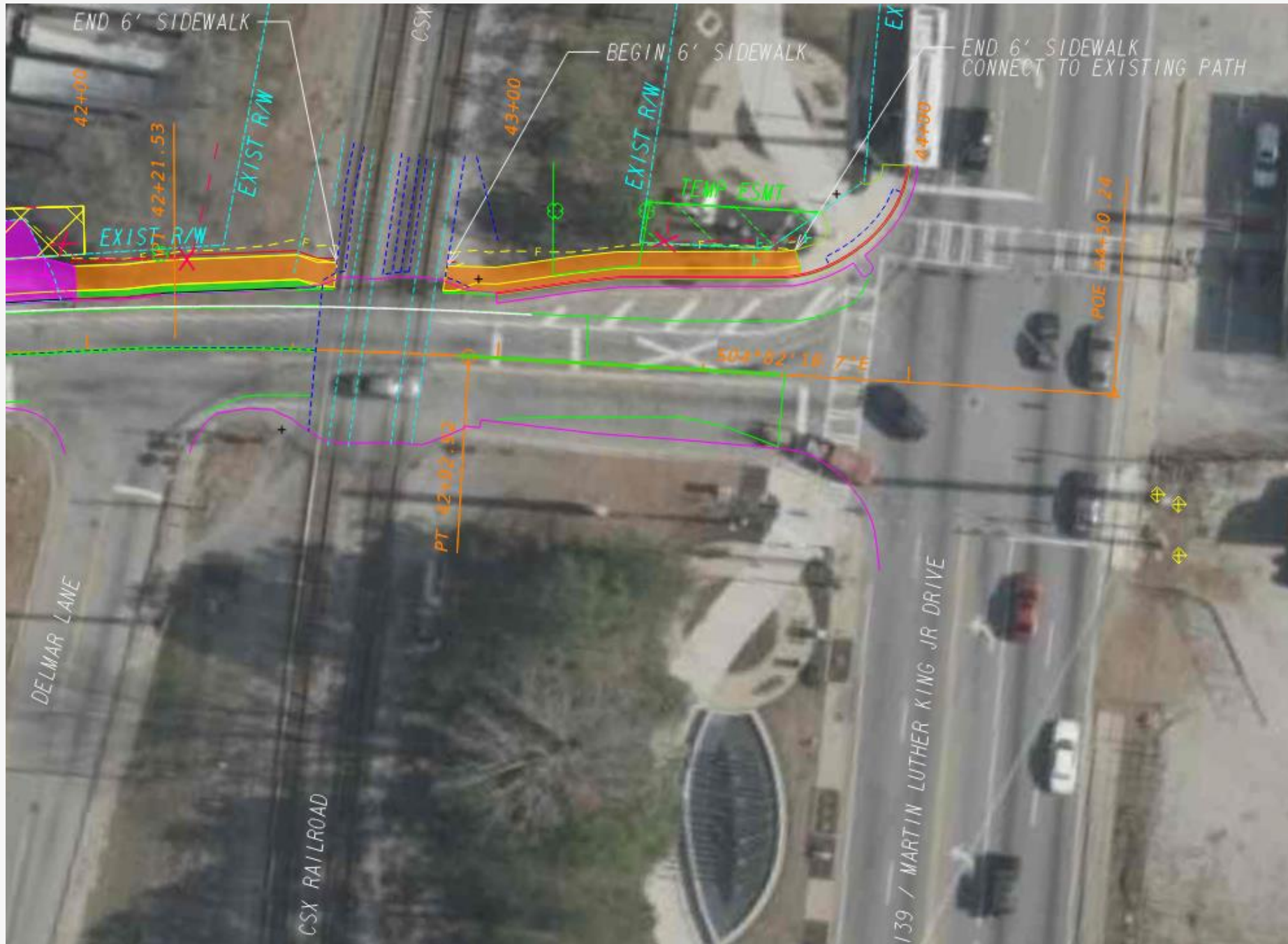

Plan View

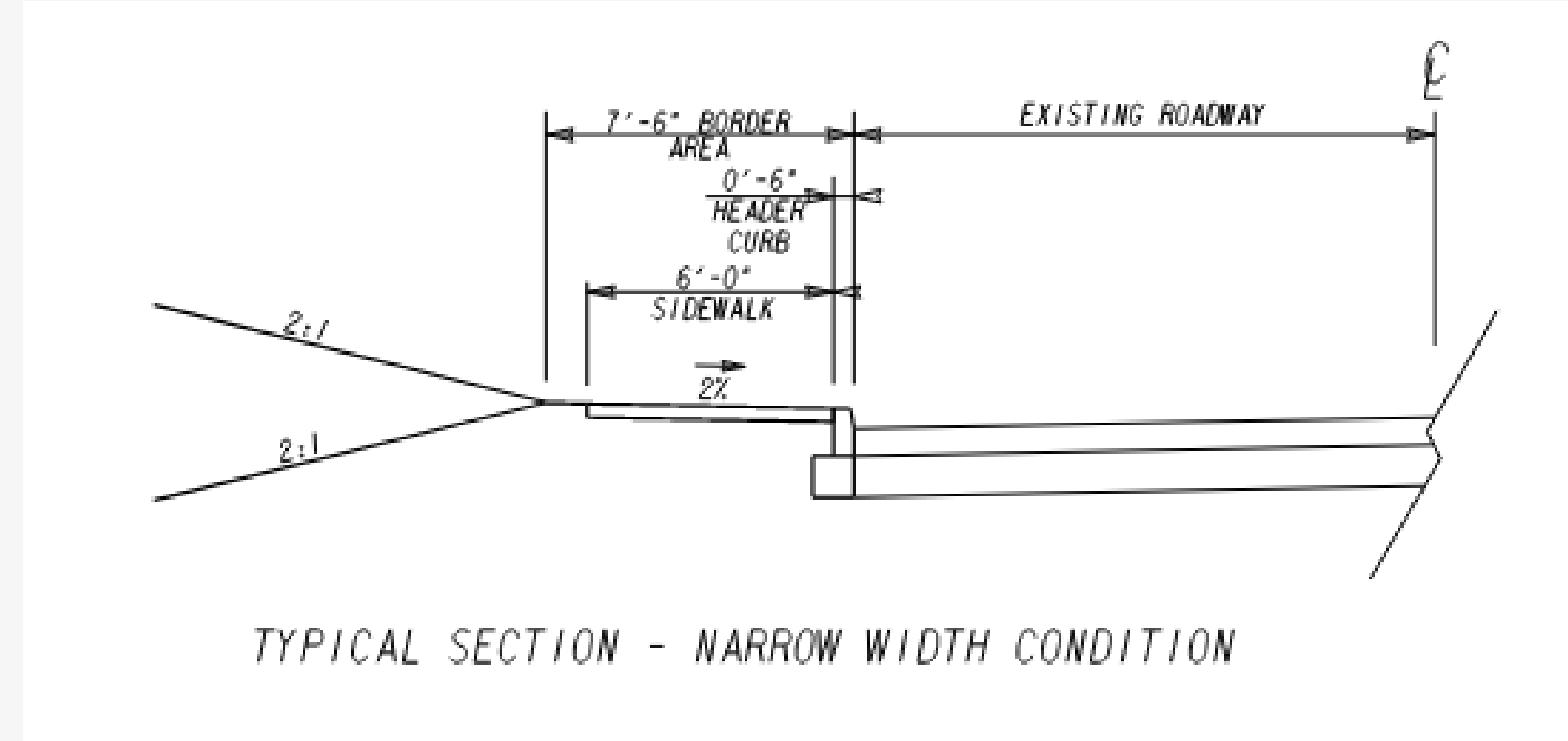

Linkwood Road Sidewalk Installation

# Existing Conditions

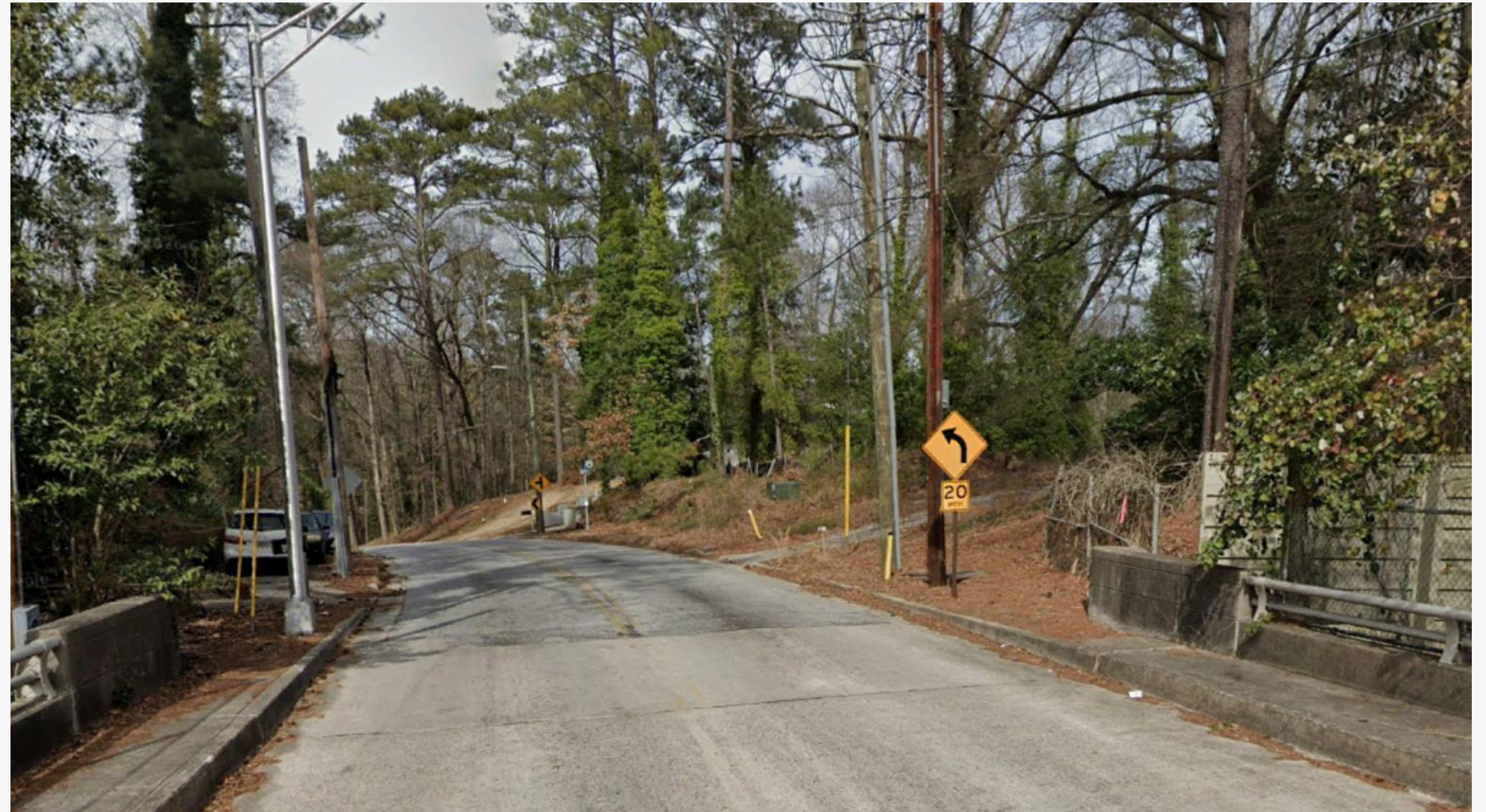

*Linkwood Rd at I-20 Bridge, facing north*

Linkwood Road Sidewalk Installation

# Existing Conditions



*Linkwood Rd at Martin Luther King Jr Dr, facing north*

# Anticipated Impacts

- **Sidewalk installation and grading slopes to existing ground will result in some tree removal and tree replacement**
- **Minor right-of-way acquisition may be required at the NE corner of Collier Dr NW and Linkwood Rd to improve turning radius and maintain new sidewalk**
- **Easement is required for the construction of slopes**
  - Ranges from 5' to 25' beyond the existing property line for grading and vegetation (or roughly 20' to 40' beyond the existing edge of pavement)
  - If there are impacts to your property, you will be notified as to the nature of those impacts.

# Next Steps

- **1<sup>st</sup> Submission Utilities (Anticipated May 2026)**
- **30% Preliminary Design Completion (Anticipated July 2026)**

# Community Discussion



# **KEEPING YOU INFORMED**

# Project Updates

## SUBSCRIBE FOR EMAIL UPDATES

- Send an email to: [atldot@atlantaga.gov](mailto:atldot@atlantaga.gov)
- Subject heading: “Linkwood Rd Sidewalk Installation Project Updates”
- Request to receive updates and meeting invitations on project referenced in heading

# Visit our website and follow us on social media

 [atldot.atlantaga.gov](http://atldot.atlantaga.gov)

 City of Atlanta Department of Transportation (ATL DOT)

 @ATL DOT

 [.com/ATL DOT](https://www.facebook.com/ATL DOT)

 @ATL DOT

 City of Atlanta Department of Transportation

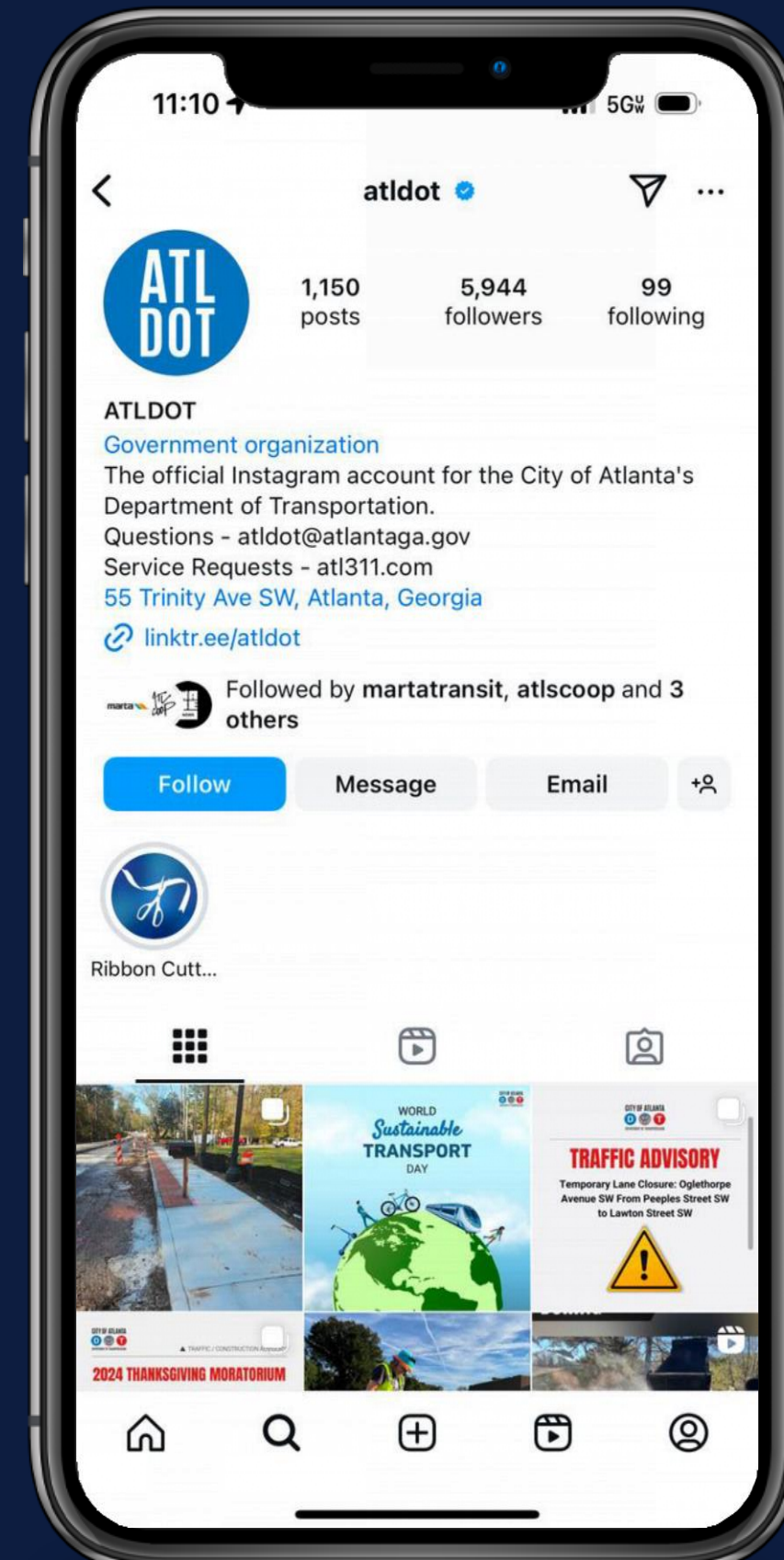
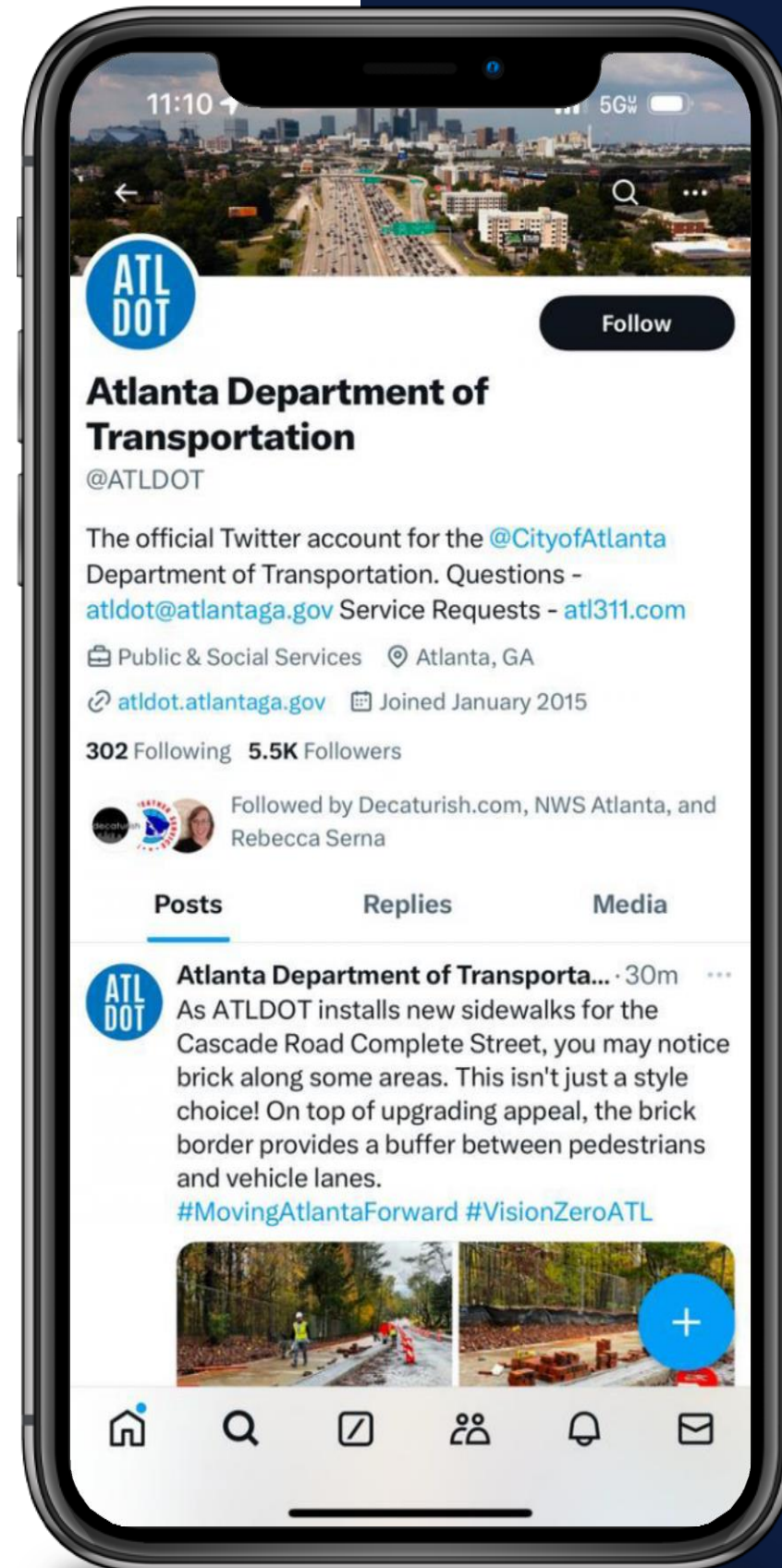

**Thank you!**